

# J125 系列调压器

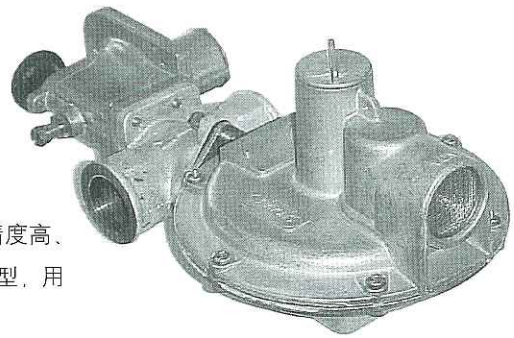

## 应用

◆ J125 系列调压器系自力式调压器、响应速度快、压力控制精度高、内置安全放散阀，分为基本型、带高压切断 / 超低压安全切断型，用于工业调压、计量站和区域分输站。

|        |  |          |   |
|--------|--|----------|---|
| 进口压力范围 | 70mbar-8.6bar                                    | 温度范围     | -20°C-70°C  |
| 出口压力范围 | 5-350mbar  | 调压精度(RG) | ± 3%  |
| 流量     | 最大到 900m <sup>3</sup> /h                         | 关闭压力(SG) | 5%  |
| 阀口尺寸   | 1/4", 3/8", 1/2", 5/8", 3/4"<br>7/8", 1", 1-1/4" | 材料       | 阀体: 铸铁 阀口: 不锈钢<br>阀垫: 丁腈合成橡胶<br>皮膜: 加强丁腈合成橡胶                                  |
| 适用介质   | 天然气、液化石油气、人工<br>煤气、混气等气体                         | 连接尺寸     | 3/4"×3/4"<br>1"×1" 1 1/2"×1 1/2"<br>2"×2" 螺纹连接<br>DN25×DN25<br>DN50×DN50 法兰连接 |

## J125 (3/4" / 1") 尺寸及型式

J125 VERSIONS The following table indicates the code numbers for the various available.

| 型号         | 全能力放散 (FR) | 部分能力放散 (LR) | 超压切断 (OPSS) | 欠压切断 (OPSS) | 安全皮膜 | 重量 (Kg) |     |
|------------|------------|-------------|-------------|-------------|------|---------|-----|
|            |            |             |             |             |      | 螺纹      | 法兰  |
| J125 - S1  |            |             |             |             |      | 1.8     | 4.5 |
| J125 - S2  |            |             |             |             |      | 1.8     | 4.5 |
| J125 - S3  | *          |             |             |             |      | 1.8     | 4.5 |
| J125 - S4  |            | *           | *           |             |      | 2.3     | 5.0 |
| J125 - S5  | *          |             | *           |             |      | 2.3     | 5.0 |
| J125 - S6  |            | *           |             | *           |      | 2.3     | 5.0 |
| J125 - S7  | *          |             |             | *           |      | 2.3     | 5.0 |
| J125 - S8  |            | *           | *           | *           |      | 2.3     | 5.0 |
| J125 - S9  | *          |             | *           | *           |      | 2.3     | 5.0 |
| J125 - S10 |            | *           | *           |             |      | 2.3     | 5.0 |
| J125 - S11 |            |             |             | *           |      | 2.3     | 5.0 |
| J125 - S12 |            |             | *           | *           |      | 2.3     | 5.0 |
| J125 - S13 |            |             | *           |             | *    | 2.3     | 5.0 |
| J125 - S14 |            |             | *           | *           | *    | 2.3     | 5.0 |

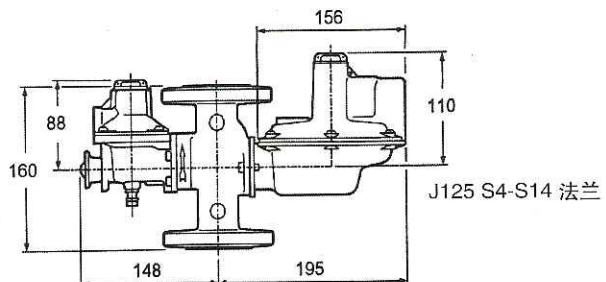
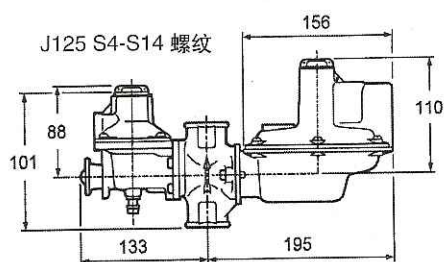
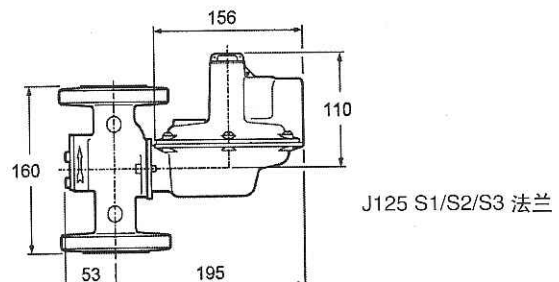
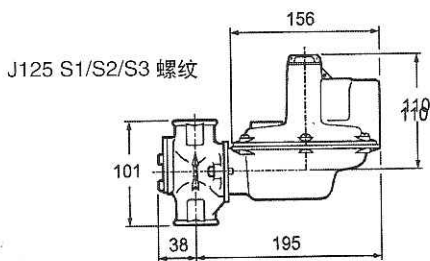

J125(3/4"/1) 调压器弹簧

| 压力 (mb) | 压力 ("WC) | 订单号 (Part No.) | 弹簧颜色 (Colour) |
|---------|----------|----------------|---------------|
| 5-15    | 2-6      | J12506-041     | 浅绿 / 黄        |
| 12-25   | 4.8-10   | J12506-042     | 浅绿 / 黑        |
| 22-35   | 8.8-14   | J12506-043     | 浅绿 / 橙        |
| 32-50   | 12.8-20  | J12506-044     | 浅绿 / 棕        |
| 45-75   | 18-30    | J12506-045     | 浅绿 / 红        |
| 72-140  | 29-56    | J12506-046     | 浅绿 / 深蓝       |

超压切断弹簧 (OPSS SPRINGS)

| 压力 (mb) | 压力 ("WC) | 订单号 (Part No.) | 弹簧颜色 (Colour) |
|---------|----------|----------------|---------------|
| 18-60   | 7.5-24   | J12506-281     | 黑             |
| 50-80   | 20-32    | J12506-282     | 橙             |
| 60-110  | 24-44    | J12506-283     | 红             |
| 100-210 | 40-84    | J12506-284     | 深绿            |
| 200-350 | 3-5PSI   | J12506-287     | 黄             |
| 280-500 | 4-7PSI   | J12506-288     | 白             |

欠压切断弹簧 (UPSS SPRINGS)

| 压力 (mb) | 压力 ("WC) | 订单号 (Part No.) | 弹簧颜色 (Colour) |
|---------|----------|----------------|---------------|
| 8-16    | 3-6      | J12506-285     | 浅蓝            |
| 16-60   | 6-24     | J12506-286     | 棕             |
| 60-150  | 24-60    | J12506-289     | 紫             |

J125 (1-1/2" / 2") 尺寸及型式

J125 VERSIONS The following table indicates the code numbers for the various J125 versions available.

| 型号         | 全能力放散 (FR) | 部分能力放散 (LR) | 超压切断 (OPSS) | 欠压切断 (OPSS) | 重量 (Kg) |      |
|------------|------------|-------------|-------------|-------------|---------|------|
|            |            |             |             |             | 螺纹      | 法兰   |
| J125 - S1  |            |             |             |             | 10.4    | 16.5 |
| J125 - S2  | *          | *           |             |             | 10.4    | 16.5 |
| J125 - S3  |            |             |             |             | 10.4    | 16.5 |
| J125 - S4  | *          | *           | *           |             | 10.9    | 17.0 |
| J125 - S5  |            |             | *           |             | 10.9    | 17.0 |
| J125 - S6  | *          | *           |             | *           | 10.9    | 17.0 |
| J125 - S7  |            |             |             | *           | 10.9    | 17.0 |
| J125 - S8  | *          | *           | *           | *           | 10.9    | 17.0 |
| J125 - S9  |            |             | *           | *           | 10.9    | 17.0 |
| J125 - S10 |            |             | *           | *           | 10.9    | 17.0 |
| J125 - S11 |            |             |             | *           | 10.9    | 17.0 |
| J125 - S12 |            |             | *           | *           | 10.9    | 17.0 |

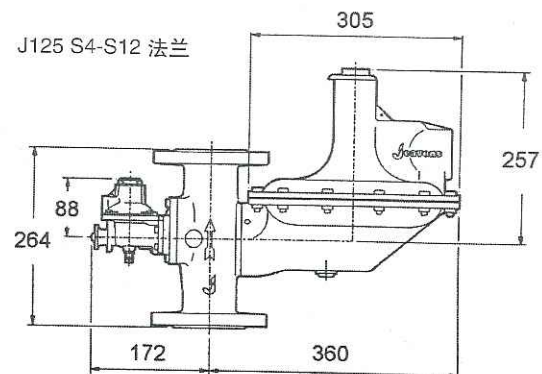
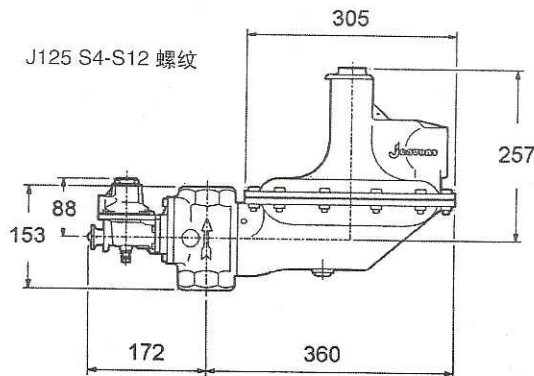
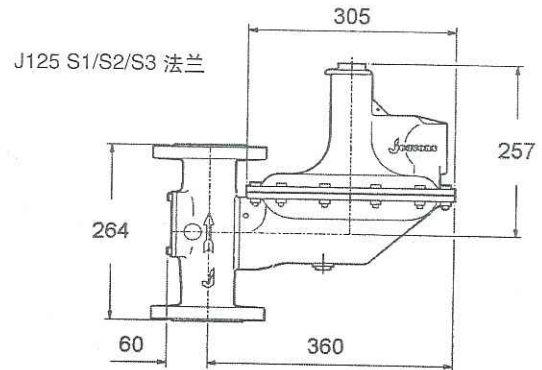
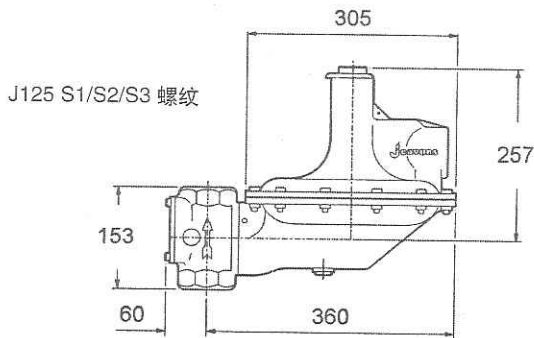

J125(1-1/2"/2")调压器弹簧

| 压力 (mb) | 压力 ("WC)   | 订单号 (Part No.) | 弹簧颜色 (Colour)         |
|---------|------------|----------------|-----------------------|
| 8.8-15  | 3.5-6      | J12509-091     | 红 (Red)               |
| 14-20   | 5.5-8      | J12509-092     | 橙 (Orange)            |
| 21-35   | 8.5-14     | J12509-093     | 黄 (Yellow)            |
| 36-70   | 14.5-28    | J12509-094     | 绿 (Green)             |
| 69-138  | 1-2PSI     | J12509-095     | 蓝 (Royal Blue)        |
| 104-173 | 1.5-2.5PSI | J12509-096     | 灰蓝 (Brown-Royal Blue) |
| 138-207 | 2-3PSI     | J12509-097     | 灰绿 (Brown-Green)      |
| 207-350 | 3-5PSI     | J12509-098     | 黑绿 (Black-Green)      |

欠压切断弹簧 (UPSS SPRINGS)

| 压力 (mb) | 压力 ("WC) | 订单号 (Part No.) | 弹簧颜色 (Colour) |
|---------|----------|----------------|---------------|
| 8-16    | 3-6      | J12506-285     | 浅蓝            |
| 16-60   | 6-24     | J12506-286     | 棕             |
| 60-150  | 24-60    | J12506-289     | 紫             |

超压切断弹簧 (OPSS SPRINGS)

| 压力 (mb) | 压力 ("WC) | 订单号 (Part No.) | 弹簧颜色 (Colour) |
|---------|----------|----------------|---------------|
| 18-60   | 7.5-24   | J12506-281     | 黑             |
| 50-80   | 20-32    | J12506-282     | 橙             |
| 60-110  | 24-44    | J12506-283     | 红             |
| 100-210 | 40-84    | J12506-284     | 深绿            |
| 200-350 | 3-5PSI   | J12506-287     | 黄             |
| 280-500 | 4-7PSI   | J12506-288     | 白             |

流量表 (Nm<sup>3</sup>/h Droop=20% 0.6sg)

J125 (1")

| 弹簧压力 (mbar) | 5-15             | 12-25 | 22-35 | 32-50 | 45-75 | 72-140 |
|-------------|------------------|-------|-------|-------|-------|--------|
| 设定压力 (mbar) | 10               | 20    | 30    | 30    | 60    | 100    |
| 进口压力 (mbar) | 流量 (阀口尺寸: 3.5mm) |       |       |       |       |        |
| 250         | 6.2              | 5.5   | 5.7   | 6.2   | 5.9   | 5.6    |
| 500         | 8.4              | 7.7   | 9.1   | 9.7   | 9.7   | 8.9    |
| 750         | 11.7             | 10.9  | 12.0  | 12.4  | 12.5  | 11.9   |
| 1000        | 15.5             | 13.7  | 14.1  | 14.0  | 14.0  | 14.8   |
| 1250        | 16.7             | 16.5  | 15.7  | 15.6  | 15.6  | 16.5   |
| 1500        | 18.5             | 18.4  | 17.8  | 17.3  | 17.3  | 18.1   |
| 2000        | 22.0             | 20.7  | 20.5  | 20.4  | 20.3  | 21.7   |
| 2500        | 25.6             | 25.3  | 24.7  | 23.9  | 23.9  | 24.6   |
| 3000        | 28.8             | 28.3  | 27.8  | 27.9  | 27.6  | 28.3   |
| 3500        | 33.1             | 32.1  | 31.3  | 30.9  | 30.9  | 31.9   |
| 4000        | 36.5             | 36.0  | 34.9  | 34.5  | 34.5  | 35.5   |
| 5000        | 43.9             | 43.9  | 44.0  | 44.1  | 44.1  | 42.8   |
| 6000        | 51.3             | 51.3  | 51.4  | 51.5  | 51.2  | 51.1   |
| 7000        | 58.5             | 58.5  | 58.2  | 58.3  | 58.4  | 58.5   |
| 8000        | 65.7             | 65.7  | 65.7  | 65.7  | 65.7  | 65.8   |

| 弹簧压力 (mbar) | 5-15           | 12-25 | 22-35 | 32-50 | 45-75 | 72-140 |
|-------------|----------------|-------|-------|-------|-------|--------|
| 设定压力 (mbar) | 10             | 20    | 30    | 30    | 60    | 100    |
| 进口压力 (mbar) | 流量 (阀口尺寸: 5mm) |       |       |       |       |        |
| 250         | 8.3            | 9.9   | 10.0  | 10.0  | 10.4  | 9.3    |
| 500         | 18.3           | 16.8  | 17.4  | 15.7  | 16.1  | 15.3   |
| 750         | 25.1           | 23.0  | 23.4  | 21.2  | 22.8  | 19.2   |
| 1000        | 28.4           | 28.9  | 28.5  | 28.6  | 27.2  | 26.1   |
| 1250        | 32.8           | 32.4  | 32.4  | 32.6  | 32.6  | 30.7   |
| 1500        | 36.7           | 36.5  | 35.5  | 35.9  | 36.4  | 34.6   |
| 2000        | 43.6           | 43.6  | 42.7  | 42.7  | 42.8  | 41.5   |
| 2500        | 50.9           | 50.3  | 49.9  | 50.2  | 51.2  | 49.7   |
| 3000        | 59.1           | 57.6  | 57.1  | 58.0  | 58.2  | 57.4   |
| 3500        | 66.3           | 64.9  | 63.7  | 65.1  | 65.1  | 64.3   |
| 4000        | 72.4           | 71.9  | 71.6  | 72.6  | 72.0  | 72.9   |
| 5000        | 85.8           | 85.8  | 85.8  | 85.8  | 85.9  | 85.9   |

| 弹簧压力 (mbar) | 5-15           | 12-25 | 22-35 | 32-50 | 45-75 | 72-140 |
|-------------|----------------|-------|-------|-------|-------|--------|
| 设定压力 (mbar) | 10             | 20    | 30    | 30    | 60    | 100    |
| 进口压力 (mbar) | 流量 (阀口尺寸: 8mm) |       |       |       |       |        |
| 100         | 13.6           | 12.8  | 12.1  | 11.3  | 9.4   | -      |
| 250         | 15.5           | 21.2  | 21.0  | 21.2  | 21.0  | 14.9   |
| 500         | 36.6           | 38.4  | 38.4  | 35.8  | 34.7  | 29.2   |
| 750         | 52.6           | 53.4  | 51.9  | 49.4  | 49.4  | 40.2   |
| 1000        | 63.5           | 62.1  | 62.5  | 62.9  | 63.9  | 47.5   |
| 1250        | 75.5           | 72.4  | 77.3  | 73.1  | 76.4  | 55.9   |
| 1500        | 81.2           | 78.9  | 87.2  | 84.0  | 83.9  | 65.8   |
| 2000        | 105.3          | 92.1  | 103.6 | 104.2 | 100.3 | 84.5   |
| 2500        | 118.4          | 111.9 | 121.7 | 120.7 | 116.8 | 108.2  |

| 弹簧压力 (mbar) | 5-15            | 12-25 | 22-35 | 32-50 | 45-75 | 72-140 |
|-------------|-----------------|-------|-------|-------|-------|--------|
| 设定压力 (mbar) | 10              | 20    | 30    | 30    | 60    | 100    |
| 进口压力 (mbar) | 流量 (阀口尺寸: 10mm) |       |       |       |       |        |
| 50          | 13.3            | 8.4   | 6.9   | -     | -     | -      |
| 100         | 14.4            | 13.7  | 12.9  | 11.9  | 9.8   | -      |
| 250         | 25.6            | 25.6  | 27.4  | 26.3  | 25.6  | 21.9   |
| 500         | 43.9            | 43.9  | 45.4  | 43.9  | 42.0  | 34.7   |
| 7500        | 62.1            | 62.8  | 65.6  | 62.1  | 62.5  | 53.0   |
| 1000        | 76.8            | 82.3  | 81.5  | 76.8  | 73.1  | 73.1   |
| 1250        | 91.4            | 95.0  | 93.6  | 91.0  | 87.7  | 89.6   |
| 1500        | 102.4           | 105.3 | 106.7 | 107.8 | 104.1 | 94.9   |
| 1700        | 113.5           | 113.5 | 117.8 | 115.2 | 115.2 | 104.2  |

J125 (11/2")

| 弹簧压力 (mbar) | 8.8-15                 | 14-20 | 21-35 | 36-70 | 69-138 | 104-173 | 138-207 | 207-345 |
|-------------|------------------------|-------|-------|-------|--------|---------|---------|---------|
| 设定压力 (mbar) | 15                     | 17.5  | 35    | 60    | 100    | 150     | 200     | 345     |
| 进口压力 (mbar) | 流量 (阀口尺寸: 1/4" 6.35mm) |       |       |       |        |         |         |         |
| 350         | 34                     | 35    | 32    | 30    | 30     | 26      | 22      | -       |
| 689         | 50                     | 51    | 49    | 50    | 47     | 38      | 45      | 35      |
| 1000        | 60                     | 60    | 59    | 58    | 58     | 56      | 55      | 55      |
| 1500        | 76                     | 76    | 75    | 72    | 72     | 75      | 70      | 75      |
| 2000        | 91                     | 92    | 91    | 90    | 85     | 95      | 90      | 95      |
| 3000        | 121                    | 121   | 121   | 126   | 115    | 120     | 110     | 115     |
| 4000        | 145                    | 150   | 155   | 155   | 145    | 155     | 140     | 150     |
| 5000        | 160                    | 165   | 175   | 175   | 170    | 180     | 170     | 175     |
| 6000        | 180                    | 185   | 180   | 185   | 180    | 190     | 180     | 185     |
| 8000        | 230                    | 230   | 240   | 230   | 230    | 240     | 215     | 225     |

| 弹簧压力 (mbar) | 8.8-15                | 14-20 | 21-35 | 36-70 | 69-138 | 104-173 | 138-207 | 207-350 |
|-------------|-----------------------|-------|-------|-------|--------|---------|---------|---------|
| 设定压力 (mbar) | 15                    | 17.5  | 35    | 60    | 100    | 150     | 200     | 345     |
| 进口压力 (mbar) | 流量 (阀口尺寸: 3/8" 9.5mm) |       |       |       |        |         |         |         |
| 69          | 20                    | 20    | -     | -     | -      | -       | -       | -       |
| 138         | 34                    | 36    | 28    | -     | -      | -       | -       | -       |
| 200         | 40                    | 42    | 38    | 38    | -      | -       | -       | -       |
| 350         | 53                    | 55    | 50    | 53    | 44     | 42      | 41      | -       |
| 689         | 76                    | 78    | 72    | 80    | 68     | 70      | 73      | 58      |
| 1000        | 87                    | 92    | 88    | 99    | 86     | 91      | 95      | 80      |
| 1500        | 104                   | 108   | 109   | 123   | 111    | 116     | 122     | 114     |
| 2000        | 119                   | 124   | 126   | 152   | 130    | 146     | 151     | 140     |
| 3000        | 140                   | 144   | 157   | 186   | 178    | 190     | 196     | 190     |
| 4000        | 160                   | 164   | 178   | 218   | 210    | 230     | 242     | 236     |
| 5000        | 180                   | 185   | 207   | 244   | 230    | 250     | 264     | 258     |
| 7000        | -                     | -     | -     | 282   | 284    | 294     | 311     | 314     |

| 弹簧压力 (mbar) | 8.8-15                 | 14-20 | 21-35 | 36-70 | 69-138 | 104-173 | 138-207 | 207-350 |
|-------------|------------------------|-------|-------|-------|--------|---------|---------|---------|
| 设定压力 (mbar) | 15                     | 17.5  | 35    | 60    | 100    | 150     | 200     | 345     |
| 进口压力 (mbar) | 流量 (阀口尺寸: 1/2" 12.7mm) |       |       |       |        |         |         |         |
| 50          | 27                     | 29    | 20    | -     | -      | -       | -       | -       |
| 69          | 33                     | 35    | 27    | -     | -      | -       | -       | -       |
| 138         | 49                     | 52    | 45    | 48    | -      | -       | -       | -       |
| 200         | 57                     | 61    | 55    | 61    | 42     | -       | -       | -       |
| 350         | 72                     | 75    | 74    | 83    | 63     | 64      | 68      | -       |
| 689         | 93                     | 97    | 102   | 115   | 95     | 105     | 114     | 90      |
| 1000        | 107                    | 111   | 121   | 135   | 118    | 131     | 149     | 125     |
| 1500        | 120                    | 124   | 142   | 166   | 152    | 167     | 182     | 174     |
| 2000        | 132                    | 137   | 157   | 182   | 180    | 198     | 222     | 211     |
| 3000        | 152                    | 157   | 182   | 212   | 219    | 246     | 282     | 274     |
| 4000        | 174                    | 178   | 208   | 234   | 251    | 292     | 322     | 326     |
| 5000        | -                      | -     | 224   | 249   | 274    | 314     | 344     | 349     |

| 弹簧压力 (mbar) | 8.8-15                 | 14-20 | 21-35 | 36-70 | 69-138 | 104-173 | 138-207 | 207-350 |
|-------------|------------------------|-------|-------|-------|--------|---------|---------|---------|
| 设定压力 (mbar) | 15                     | 17.5  | 35    | 60    | 100    | 150     | 200     | 345     |
| 进口压力 (mbar) | 流量 (阀口尺寸: 5/8" 15.9mm) |       |       |       |        |         |         |         |
| 50          | 32                     | 33    | -     | -     | -      | -       | -       | -       |
| 69          | 38                     | 40    | 32    | -     | -      | -       | -       | -       |
| 138         | 53                     | 56    | 49    | 67    | -      | -       | -       | -       |
| 200         | 60                     | 64    | 58    | 75    | 54     | -       | -       | -       |
| 350         | 72                     | 76    | 75    | 99    | 77     | 77      | 78      | -       |
| 689         | 89                     | 93    | 96    | 129   | 115    | 120     | 128     | 104     |
| 1000        | 100                    | 105   | 115   | 149   | 137    | 146     | 167     | 141     |
| 1500        | 113                    | 120   | 132   | 170   | 170    | 184     | 207     | 195     |
| 2000        | 142                    | 128   | 148   | 190   | 196    | 211     | 239     | 225     |
| 3000        | -                      | 149   | 173   | 210   | 233    | 254     | 287     | 288     |
| 4000        | -                      | -     | 194   | 230   | 259    | 287     | 324     | 338     |
| 5000        | -                      | -     | -     | -     | 270    | 304     | 344     | 360     |

| 弹簧压力 (mbar) | 8.8-15                 | 14-20 | 21-35 | 36-70 | 69-138 | 104-173 | 138-207 | 207-350 |
|-------------|------------------------|-------|-------|-------|--------|---------|---------|---------|
| 设定压力 (mbar) | 15                     | 17.5  | 35    | 60    | 100    | 150     | 200     | 345     |
| 进口压力 (mbar) | 流量 (阀口尺寸: 3/4" 19.1mm) |       |       |       |        |         |         |         |
| 50          | 40                     | 43    | -     | -     | -      | -       | -       | -       |
| 69          | 48                     | 51    | 37    | -     | -      | -       | -       | -       |
| 138         | 64                     | 68    | 57    | 71    | -      | -       | -       | -       |
| 200         | 72                     | 77    | 70    | 86    | 58     | -       | -       | -       |
| 350         | 90                     | 93    | 90    | 112   | 87     | 88      | 96      | -       |
| 689         | 113                    | 115   | 120   | 150   | 123    | 137     | 154     | 124     |
| 1000        | 127                    | 129   | 138   | 167   | 154    | 171     | 188     | 168     |
| 1500        | 150                    | 154   | 163   | 193   | 181    | 202     | 238     | 220     |
| 2000        | 170                    | 174   | 183   | 212   | 210    | 240     | 274     | 266     |
| 3000        | 194                    | 196   | 213   | 244   | 260    | 283     | 340     | 335     |
| 4000        | -                      | -     | 242   | 273   | 285    | 322     | 397     | 416     |
| 5000        | -                      | -     | -     | 281   | 297    | 336     | 414     | 434     |

| 弹簧压力 (mbar) | 8.8-15                 | 14-20 | 21-35 | 36-70 | 69-138 | 104-173 | 138-207 | 207-350 |
|-------------|------------------------|-------|-------|-------|--------|---------|---------|---------|
| 设定压力 (mbar) | 15                     | 17.5  | 35    | 60    | 100    | 150     | 200     | 345     |
| 进口压力 (mbar) | 流量 (阀口尺寸: 7/8" 22.2mm) |       |       |       |        |         |         |         |
| 50          | 41                     | 45    | -     | -     | -      | -       | -       | -       |
| 69          | 51                     | 56    | -     | -     | -      | -       | -       | -       |
| 138         | 70                     | 76    | 67    | -     | -      | -       | -       | -       |
| 200         | 79                     | 86    | 85    | 98    | -      | -       | -       | -       |
| 350         | 95                     | 12    | 109   | 131   | 100    | 102     | 109     | -       |
| 689         | 123                    | 130   | 145   | 179   | 150    | 167     | 193     | 162     |
| 1000        | 146                    | 154   | 172   | 198   | 190    | 206     | 226     | 210     |
| 1500        | 182                    | 188   | 203   | 236   | 234    | 257     | 288     | 279     |
| 2000        | -                      | -     | 231   | 266   | 274    | 300     | 344     | 340     |
| 2500        | -                      | -     | 189   | 215   | 215    | 246     | 285     | 270     |
| 3000        | -                      | -     | -     | -     | 332    | 366     | 433     | 440     |

| 弹簧压力 (mbar) | 8.5-15               | 14-20 | 21-35 | 36-70 | 69-138 | 104-173 | 138-207 | 207-350 |
|-------------|----------------------|-------|-------|-------|--------|---------|---------|---------|
| 设定压力 (mbar) | 15                   | 17.5  | 35    | 60    | 100    | 150     | 200     | 345     |
| 进口压力 (mbar) | 流量 (阀口尺寸: 1" 25.4mm) |       |       |       |        |         |         |         |
| 50          | 47                   | 51    | 40    | -     | -      | -       | -       | -       |
| 69          | 54                   | 57    | 49    | -     | -      | -       | -       | -       |
| 138         | 71                   | 76    | 73    | -     | -      | -       | -       | -       |
| 200         | 77                   | 84    | 84    | 105   | 70     | 73      | -       | -       |
| 350         | 94                   | 99    | 108   | 131   | 105    | 115     | 120     | 130     |
| 689         | 121                  | 126   | 136   | 167   | 150    | 179     | 198     | 163     |
| 1000        | 135                  | 138   | 158   | 190   | 180    | 210     | 230     | 207     |
| 1500        | -                    | -     | 189   | 215   | 215    | 246     | 285     | 270     |
| 2000        | -                    | -     | -     | 235   | 245    | 278     | 319     | 320     |

| 弹簧压力 (mbar) | 8.5-15                   | 14-20 | 21-35 | 36-70 | 69-138 | 104-173 | 138-207 | 207-350 |
|-------------|--------------------------|-------|-------|-------|--------|---------|---------|---------|
| 设定压力 (mbar) | 15                       | 17.5  | 35    | 60    | 100    | 150     | 200     | 345     |
| 进口压力 (mbar) | 流量 (阀口尺寸: 1-1/4" 31.8mm) |       |       |       |        |         |         |         |
| 50          | 43                       | 45    | 48    | -     | -      | -       | -       | -       |
| 69          | 50                       | 53    | 56    | -     | -      | -       | -       | -       |
| 138         | 66                       | 73    | 82    | 96    | -      | -       | -       | -       |
| 200         | 78                       | 82    | 92    | 117   | 83     | -       | -       | -       |
| 350         | 94                       | 97    | 117   | 143   | 122    | 141     | 144     | -       |
| 689         | -                        | -     | 149   | 178   | 174    | 208     | 210     | 195     |
| 1000        | -                        | -     | 171   | 201   | 210    | 231     | 247     | 239     |
| 1500        | -                        | -     | -     | -     | 234    | 269     | 296     | 306     |
| 2000        | -                        | -     | -     | -     | -      | 304     | 333     | 360     |

J125 (2")

| 弹簧压力 (mbar) | 8.8-15          | 14-20 | 21-35 | 36-70 | 69-138 | 104-173 | 138-207 | 207-350 |
|-------------|-----------------|-------|-------|-------|--------|---------|---------|---------|
| 设定压力 (mbar) | 15              | 17.5  | 35    | 60    | 100    | 150     | 200     | 345     |
| 进口压力 (mbar) | 流量 (阀口尺寸: 1/4") |       |       |       |        |         |         |         |
| 350         | 35              | 35    | 35    | 37    | 25     | 26      | 22      | -       |
| 689         | 45              | 50    | 50    | 46    | 40     | 38      | 45      | 35      |
| 1000        | 60              | 60    | 60    | 60    | 55     | 56      | 55      | 55      |
| 1500        | 75              | 80    | 70    | 80    | 75     | 75      | 70      | 75      |
| 2000        | 85              | 90    | 95    | 90    | 95     | 95      | 90      | 95      |
| 3000        | 125             | 125   | 120   | 120   | 120    | 120     | 110     | 115     |
| 4000        | 155             | 150   | 155   | 155   | 145    | 155     | 140     | 150     |
| 5000        | 160             | 165   | 175   | 175   | 170    | 180     | 170     | 175     |
| 6000        | 180             | 185   | 180   | 185   | 180    | 190     | 180     | 185     |
| 8000        | 230             | 230   | 240   | 230   | 230    | 240     | 215     | 225     |

J125 5mm (3/8")

| 弹簧压力 (mbar) | 8.8-15          | 14-20 | 21-35 | 36-70 | 69-138 | 104-173 | 138-207 | 207-350 |
|-------------|-----------------|-------|-------|-------|--------|---------|---------|---------|
| 设定压力 (mbar) | 15              | 17.5  | 35    | 60    | 100    | 150     | 200     | 345     |
| 进口压力 (mbar) | 流量 (阀口尺寸: 3/8") |       |       |       |        |         |         |         |
| 69          | 30              | 30    | 25    | -     | -      | -       | -       | -       |
| 138         | 40              | 40    | 35    | -     | -      | -       | -       | -       |
| 200         | 50              | 50    | 45    | 45    | -      | -       | -       | -       |
| 350         | 70              | 70    | 60    | 65    | 50     | 55      | 55      | -       |
| 689         | 100             | 100   | 90    | 100   | 80     | 90      | 95      | 75      |
| 1000        | 125             | 125   | 120   | 125   | 105    | 115     | 125     | 100     |
| 1500        | 155             | 155   | 155   | 155   | 135    | 150     | 160     | 135     |
| 2000        | 185             | 190   | 190   | 190   | 165    | 190     | 190     | 170     |
| 3000        | 245             | 250   | 250   | 255   | 230    | 250     | 255     | 230     |
| 4000        | 310             | 315   | 315   | 315   | 300    | 315     | 315     | 300     |
| 5000        | 330             | 335   | 340   | 345   | 335    | 335     | 340     | 335     |
| 7000        | -               | -     | -     | 405   | 400    | 405     | 415     | 410     |

J125 12.7mm (1/2")

| 弹簧压力 (mbar) | 8.5-15          | 14-20 | 21-35 | 36-70 | 69-138 | 104-173 | 138-207 | 207-350 |
|-------------|-----------------|-------|-------|-------|--------|---------|---------|---------|
| 设定压力 (mbar) | 15              | 17.5  | 35    | 60    | 100    | 150     | 200     | 345     |
| 进口压力 (mbar) | 流量 (阀口尺寸: 1/2") |       |       |       |        |         |         |         |
| 50          | 25              | 30    | 25    | -     | -      | -       | -       | -       |
| 69          | 30              | 35    | 30    | -     | -      | -       | -       | -       |
| 138         | 50              | 55    | 45    | 50    | -      | -       | -       | -       |
| 200         | 70              | 75    | 60    | 65    | 40     | 40      | -       | -       |
| 350         | 100             | 110   | 85    | 100   | 85     | 70      | 80      | -       |
| 689         | 150             | 160   | 130   | 145   | 105    | 115     | 135     | 90      |
| 1000        | 190             | 200   | 165   | 190   | 135    | 150     | 180     | 130     |
| 1500        | 245             | 255   | 225   | 250   | 180    | 205     | 240     | 180     |
| 2000        | 295             | 305   | 275   | 305   | 225    | 255     | 300     | 225     |
| 3000        | 380             | 410   | 390   | 430   | 315    | 355     | 420     | 315     |
| 4000        | 430             | 460   | 515   | 540   | 440    | 480     | 530     | 435     |
| 5000        | -               | -     | 580   | 580   | 540    | 550     | 580     | 535     |

J125 15.9mm (5/8")

| 弹簧压力 (mbar) | 8.5-15          | 14-20 | 21-35 | 36-70 | 69-138 | 104-173 | 138-207 | 207-350 |
|-------------|-----------------|-------|-------|-------|--------|---------|---------|---------|
| 设定压力 (mbar) | 15              | 17.5  | 35    | 60    | 100    | 150     | 200     | 345     |
| 进口压力 (mbar) | 流量 (阀口尺寸: 5/8") |       |       |       |        |         |         |         |
| 50          | 35              | 38    | -     | -     | -      | -       | -       | -       |
| 69          | 45              | 48    | 30    | -     | -      | -       | -       | -       |
| 138         | 75              | 80    | 55    | -     | -      | -       | -       | -       |
| 200         | 90              | 95    | 65    | 85    | 50     | -       | -       | -       |
| 350         | 130             | 135   | 95    | 120   | 70     | 80      | 80      | -       |
| 689         | 205             | 210   | 150   | 190   | 115    | 135     | 135     | 115     |
| 1000        | 260             | 265   | 205   | 240   | 145    | 185     | 185     | 165     |
| 1500        | 335             | 345   | 285   | 320   | 195    | 245     | 255     | 230     |
| 2000        | 380             | 400   | 360   | 400   | 255    | 315     | 320     | 295     |
| 3000        | 445             | 470   | 525   | 555   | 370    | 455     | 465     | 420     |
| 4000        | -               | -     | 670   | 705   | 520    | 600     | 605     | 545     |
| 6000        | -               | -     | -     | -     | -      | 700     | 700     | 640     |

| 弹簧压力 (mbar) | 8.8-15          | 14-20 | 21-35 | 36-70 | 69-138 | 104-173 | 138-207 | 207-350 |
|-------------|-----------------|-------|-------|-------|--------|---------|---------|---------|
| 设定压力 (mbar) | 15              | 17.5  | 35    | 60    | 100    | 150     | 200     | 345     |
| 进口压力 (mbar) | 流量 (阀口尺寸: 3/4") |       |       |       |        |         |         |         |
| 50          | 35              | 45    | -     | -     | -      | -       | -       | -       |
| 69          | 45              | 60    | 45    | -     | -      | -       | -       | -       |
| 138         | 70              | 85    | 75    | 90    | -      | -       | -       | -       |
| 200         | 90              | 110   | 100   | 120   | 65     | -       | -       | -       |
| 350         | 130             | 145   | 135   | 165   | 105    | 130     | 135     | -       |
| 689         | 190             | 205   | 200   | 250   | 155    | 2058    | 220     | 170     |
| 1000        | 235             | 250   | 250   | 300   | 210    | 265     | 290     | 235     |
| 1500        | 320             | 330   | 330   | 390   | 275    | 355     | 400     | 325     |
| 2000        | 370             | 395   | 420   | 485   | 350    | 455     | 500     | 415     |
| 3000        | 465             | 490   | 565   | 600   | 515    | 610     | 655     | 590     |
| 4000        | -               | -     | 600   | 655   | 615    | 690     | 760     | 760     |
| 5000        | -               | -     | -     | 670   | 625    | 700     | 785     | 785     |

| 弹簧压力 (mbar) | 8.8-15          | 14-20 | 21-35 | 36-70 | 69-138 | 104-173 | 138-207 | 207-350 |
|-------------|-----------------|-------|-------|-------|--------|---------|---------|---------|
| 设定压力 (mbar) | 15              | 17.5  | 35    | 60    | 100    | 150     | 200     | 345     |
| 进口压力 (mbar) | 流量 (阀口尺寸: 7/8") |       |       |       |        |         |         |         |
| 50          | 40              | 45    | -     | -     | -      | -       | -       | -       |
| 69          | 45              | 55    | -     | -     | -      | -       | -       | -       |
| 138         | 70              | 85    | 80    | -     | -      | -       | -       | -       |
| 200         | 95              | 110   | 100   | 125   | -      | -       | -       | -       |
| 350         | 130             | 145   | 140   | 170   | 105    | 120     | 125     | -       |
| 689         | 195             | 205   | 205   | 240   | 160    | 190     | 215     | 165     |
| 1000        | 240             | 250   | 250   | 295   | 210    | 250     | 285     | 225     |
| 1500        | 320             | 330   | 330   | 390   | 290    | 335     | 375     | 310     |
| 2000        | -               | -     | 420   | 490   | 360    | 430     | 485     | 390     |
| 2500        | -               | -     | -     | 560   | 440    | 520     | 580     | 475     |
| 3000        | -               | -     | -     | -     | 540    | 605     | 645     | 545     |

| 弹簧压力 (mbar) | 8.8-15        | 14-20 | 21-35 | 36-70 | 69-138 | 104-173 | 138-207 | 207-350 |
|-------------|---------------|-------|-------|-------|--------|---------|---------|---------|
| 设定压力 (mbar) | 15            | 17.5  | 35    | 60    | 100    | 150     | 200     | 345     |
| 进口压力 (mbar) | 流量 (阀口尺寸: 1") |       |       |       |        |         |         |         |
| 50          | 50            | 45    | 40    | -     | -      | -       | -       | -       |
| 69          | 65            | 58    | 48    | -     | -      | -       | -       | -       |
| 138         | 100           | 95    | 75    | -     | -      | -       | -       | -       |
| 200         | 135           | 125   | 100   | 140   | 75     | 90      | -       | -       |
| 350         | 175           | 168   | 135   | 180   | 120    | 140     | 80      | -       |
| 689         | 265           | 260   | 230   | 300   | 190    | 230     | 150     | 170     |
| 1000        | 330           | 335   | 305   | 360   | 250    | 300     | 210     | 245     |
| 1500        | -             | -     | 371   | 416   | 330    | 330     | 300     | 360     |
| 3600        | -             | -     | -     | -     | 420    | 510     | 375     | 460     |

| 弹簧压力 (mbar) | 8.8-15            | 14-20 | 21-35 | 36-70 | 69-138 | 104-173 | 138-207 | 207-350 |
|-------------|-------------------|-------|-------|-------|--------|---------|---------|---------|
| 设定压力 (mbar) | 15                | 17.5  | 35    | 60    | 100    | 150     | 200     | 345     |
| 进口压力 (mbar) | 流量 (阀口尺寸: 1 1/4") |       |       |       |        |         |         |         |
| 50          | 65                | 60    | 50    | -     | -      | -       | -       | -       |
| 69          | 80                | 80    | 80    | -     | -      | -       | -       | -       |
| 138         | 130               | 125   | 105   | -     | -      | -       | -       | -       |
| 200         | 165               | 165   | 135   | 180   | 110    | -       | -       | -       |
| 350         | 220               | 220   | 190   | 245   | 150    | 80      | 160     | -       |
| 689         | -                 | -     | 290   | 365   | 240    | 280     | 290     | 215     |
| 1000        | -                 | -     | 380   | 450   | 325    | 345     | 390     | 315     |
| 1500        | -                 | -     | -     | -     | 460    | 490     | 520     | 465     |
| 2000        | -                 | -     | -     | -     | -      | 600     | 630     | 570     |